

# HINDI

# 880

- ELECTRO-HYDRAULIC OPERATOR
- TWO-WAY HYDRAULIC LOCKING

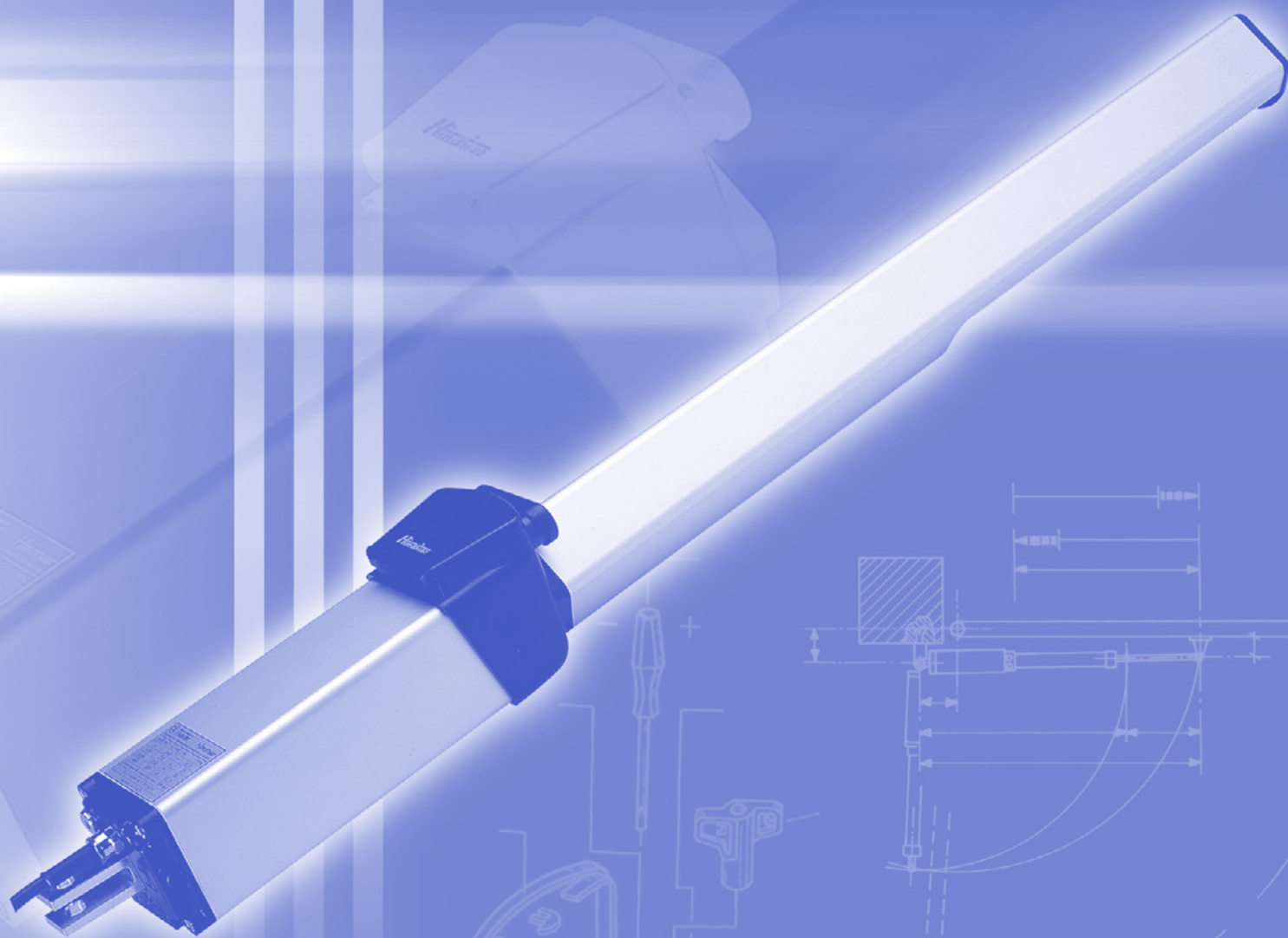

**INSTALLATION MANUAL**

GB

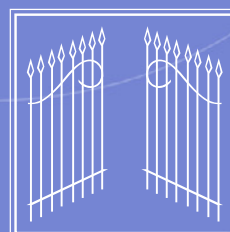

**FADINI**<sup>®</sup>  
the gate opener

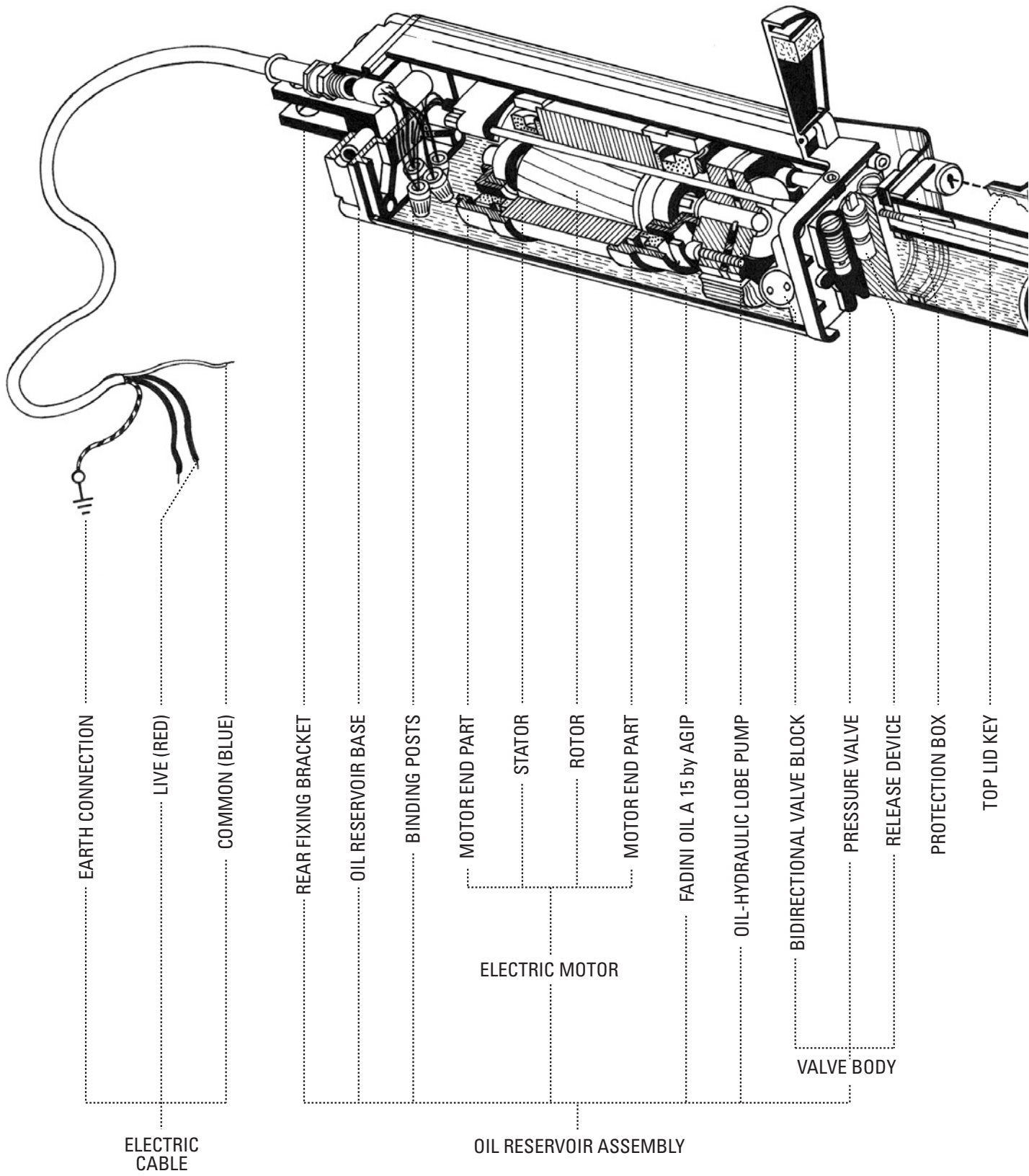

# CUTAWAY GENERAL VIEW

# Hindi880<sup>®</sup>

## OIL-HYDRAULIC OPERATOR FOR SWINGING GATES. ABOVE GROUND

Two-way locking in Open/Close gate position

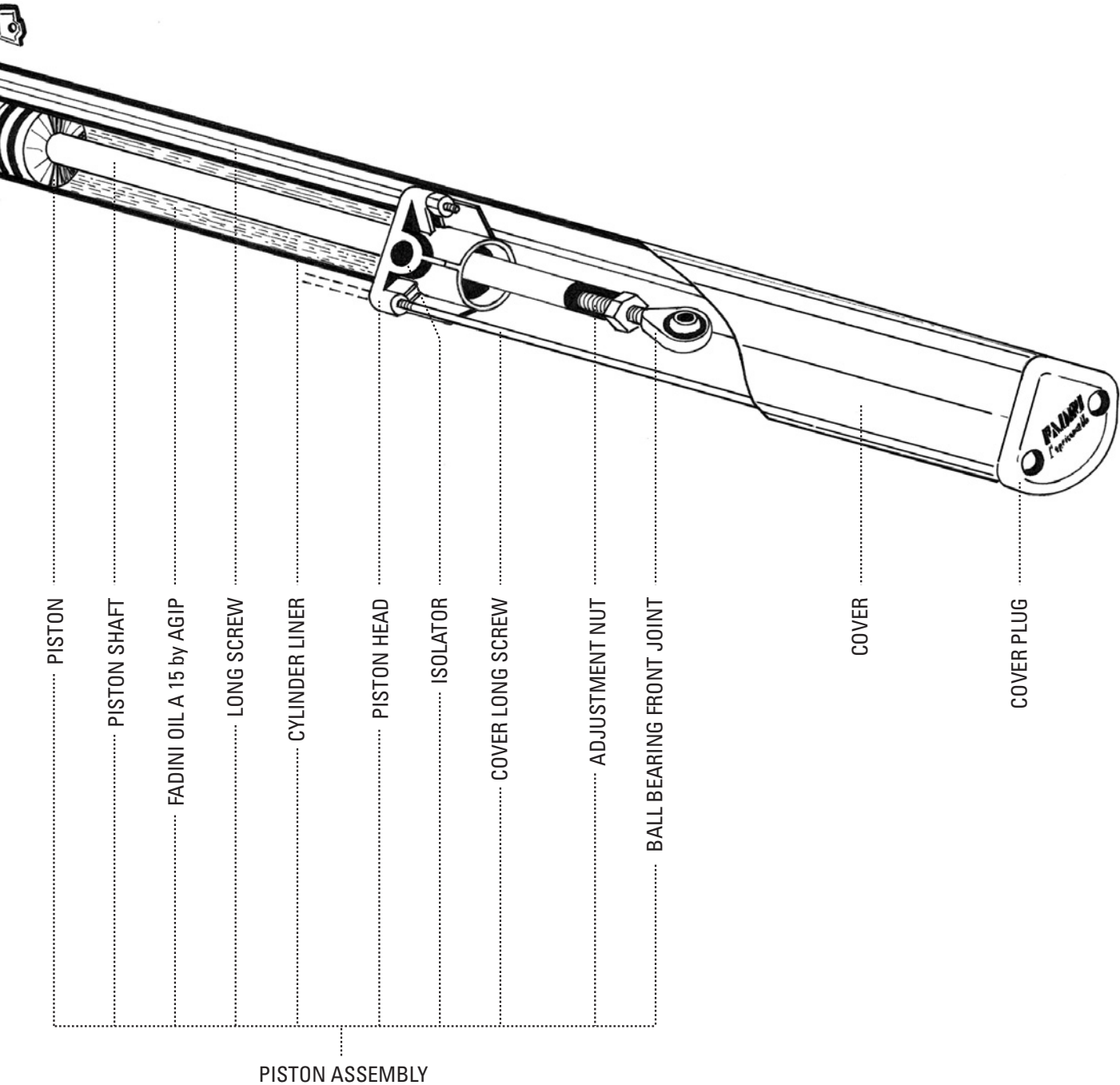

PIC. 1

# INSTRUCTIONS FOR THE INSTALLATION OF HINDI 880, AN ELECTRO-HYDRAULIC OPERATOR, TWO-WAY LOCKING IN OPEN AND CLOSE GATE POSITION.

Keep to the following to achieve a perfectly working system.

HINDI 880, strong, functional and easy to install, is designed to be fitted to swinging gates by means of two plates, one is to be fixed to the gate and the other one to the gate post, pillar or brick pier. Check parts as in picture No. 2.

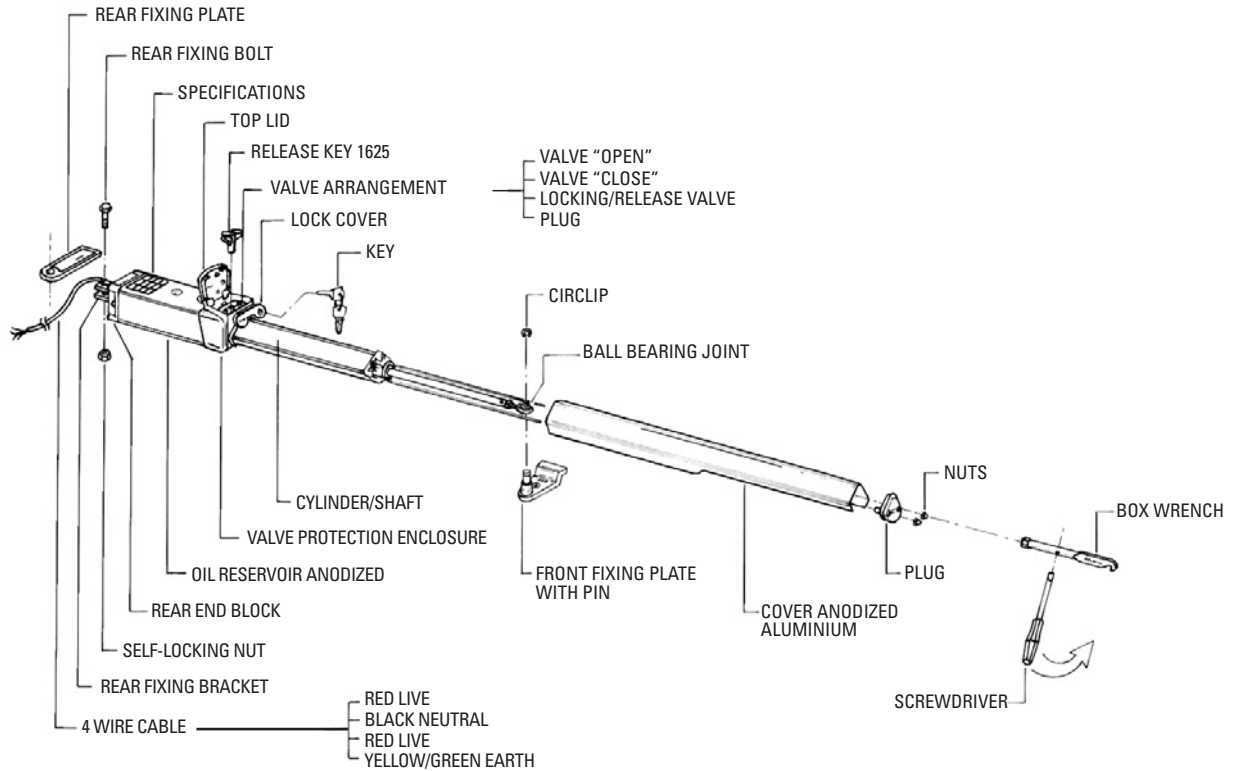

**PIC. 2**

First unscrew the two nuts in the front end cap and remove the anodized, aluminium cover by pulling it horizontally and lay bare the cylinder, shaft and ball bearing joint for fitting and setting operations. Reinforcement plates are to be provided as shown in the pictures. Fixing to the gate post is by screwing, welding or setting with concret depending on the type of posts involved. Reinforcement plates fitted with anchor ended wedges are recommended for better grip in case of brick piers. Distances are strictly as shown in picture 3.

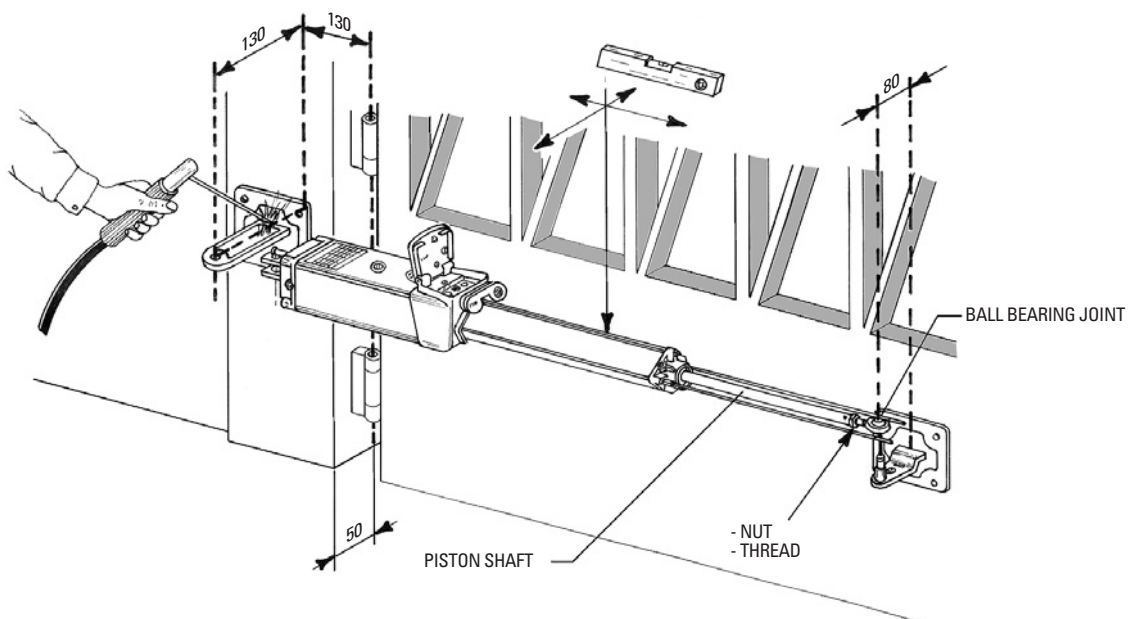

**PIC. 3**

Provide a temporary fixing for the front fixing plate to the gate and swing the operator on to it. The shaft must be fully out, and the ball bearing joint fully screwed in, the gates in close position. Check alignment of the operators by means of a level. Picture 3.

In events like power failure, HINDI 880 two- or one-way locking is designed to be released so that the gates can be pushed open by hand. Picture No. 4 shows how to do it. Lift the flap cover that protects the lock and open the top lid. Inside you will find the special release key part No. 1625. Turn it anti-clockwise by one complete turn. Should the gates be so wide that an electric lock is required for a better hold, after releasing the operator, remember to release the electric lock as well by its proper key, and then push the gates open. See picture 11-12.

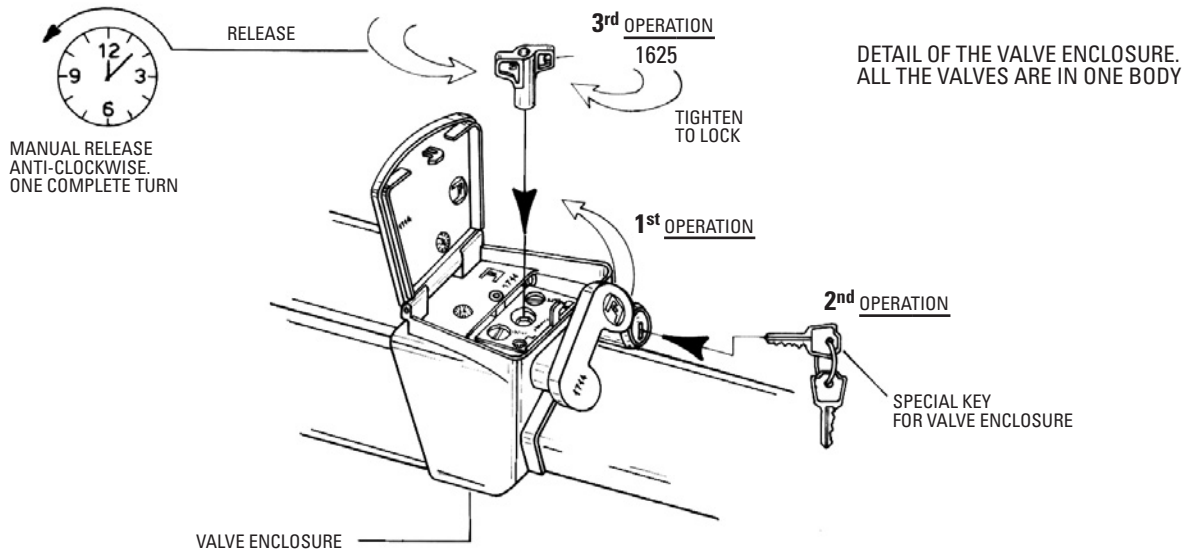

**PIC. 4**

Before definitely fixing the front fixing plate to the gate, carry out some performance tests, the ball bearing joint still fully screwed in. Let the shaft come out to its full extension so to check if the above plate is in the correct position and fix it by welding. See picture 5.

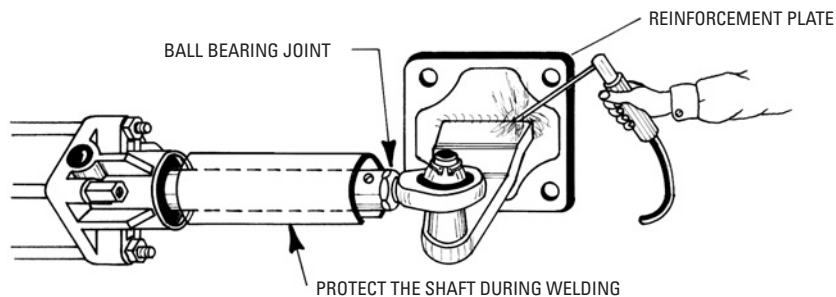

**PIC. 5**

After fixing the plate to the gate, it is important to unscrew the ball bearing joint by 5 or 6 mm, then re-tighten the nut. A sort of oil cushion is created in this way between the operator end casting "T" and the piston "S". Pic. 6. This will prevent the ram from reaching the very limit of the permitted stroke and the gates are firmly held in closed gate position, as shown in pic. 10 on page 7.

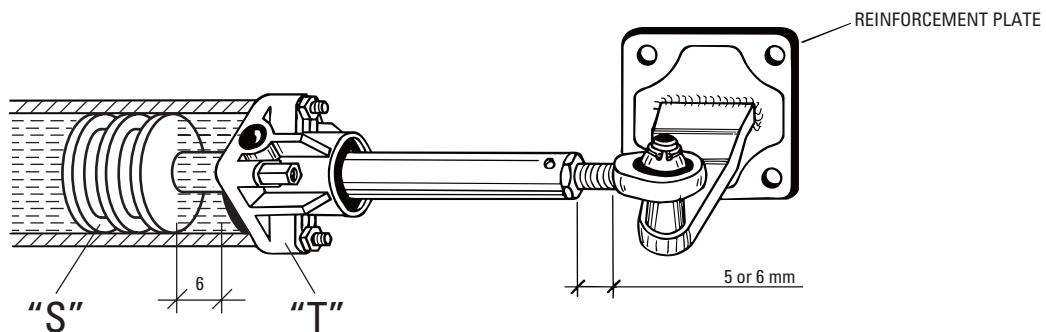

**PIC. 6**

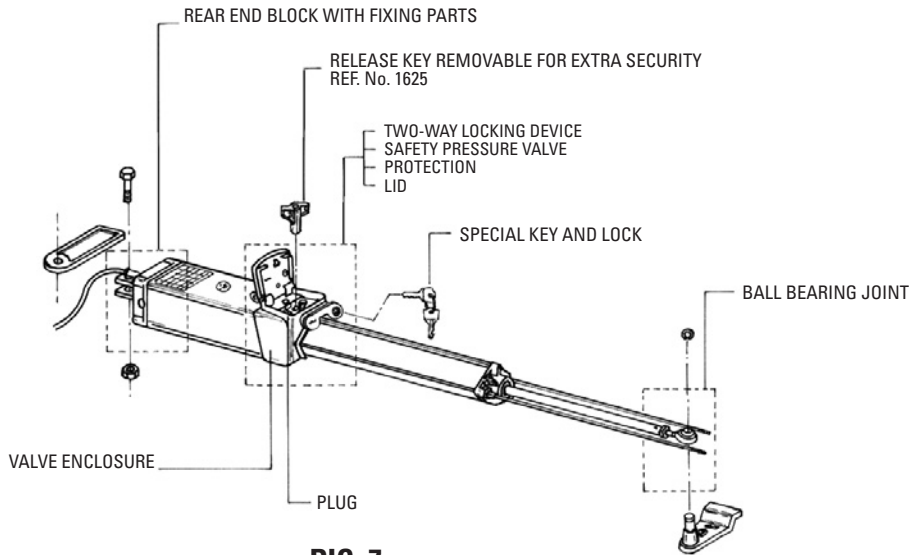

**PIC. 7**

Make sure that the distances A and B are A 130 mm and B 130 mm, the centre of the gate hinge and the centre of the rear bracket of the operator to be referred to respectively. Distance D is never to be varied and must be equal to 80 mm from the centre of the ball bearing joint to the gate surface. Picture 8.

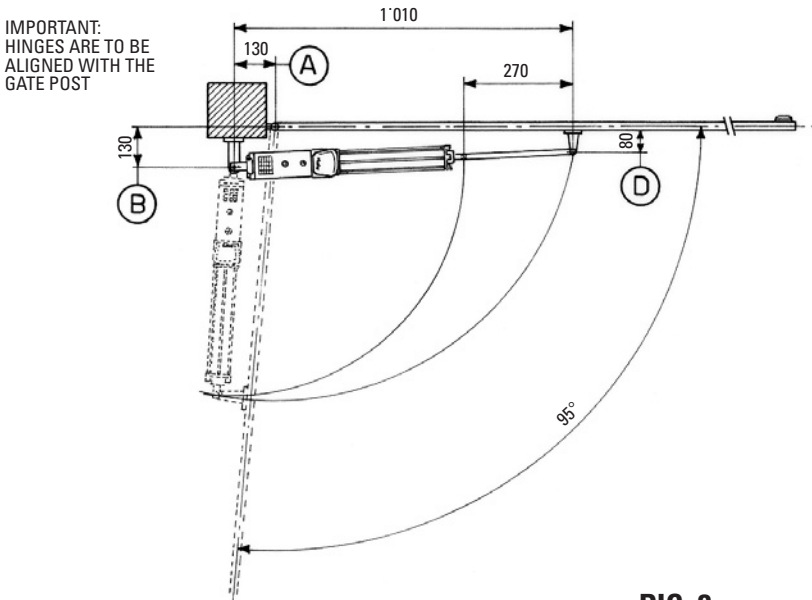

Open the valve enclosure by using the supplied key and release the operator by means of the special key No. 1625 which comes inside the enclosure, already fitted on the release valve. The shaft will now be allowed to move freely in and out by pushing the gates by hand in a very smooth way. One complete cycle (open and close) is recommended so that the piston reaches the limit of the permitted stroke. Picture 7.

**PIC. 8**

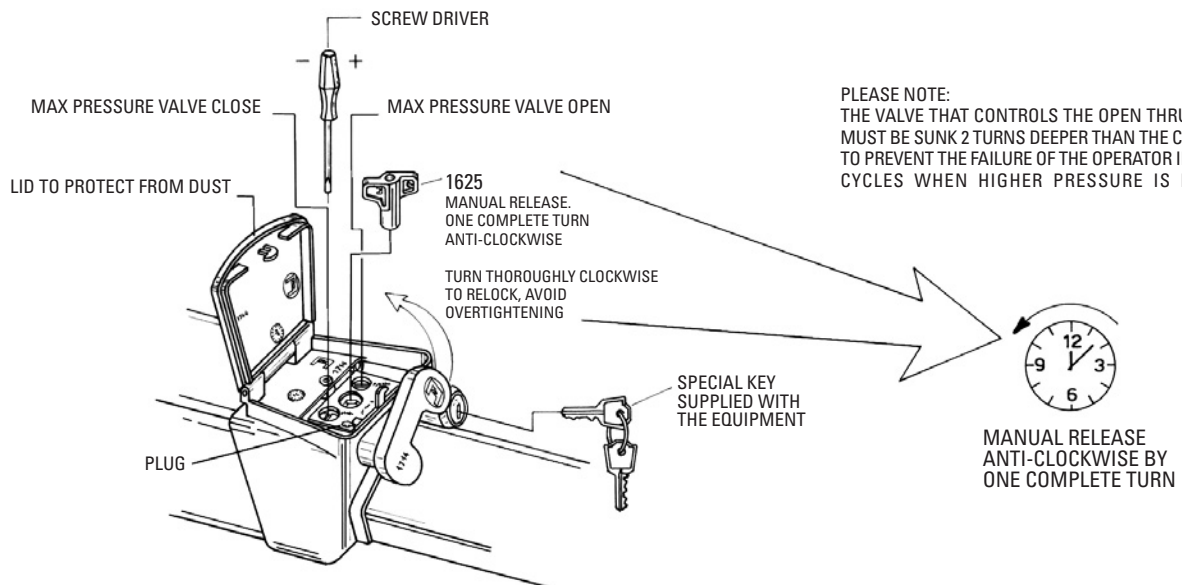

**PIC. 9**

Fit the gates with an electric lock in case it is installed the non locking operator. With the two-way locking operator it is recommended that the gates are not wider than two meters each. Should they be more than two meters an electric lock is to be installed to help the gates to be firmly held in the close position. Picture 10.

With single gates the electric lock is to be installed horizontally at a suitable height from ground level. With double gates it is to be fitted vertically at the foot of the gates. Picture 11.

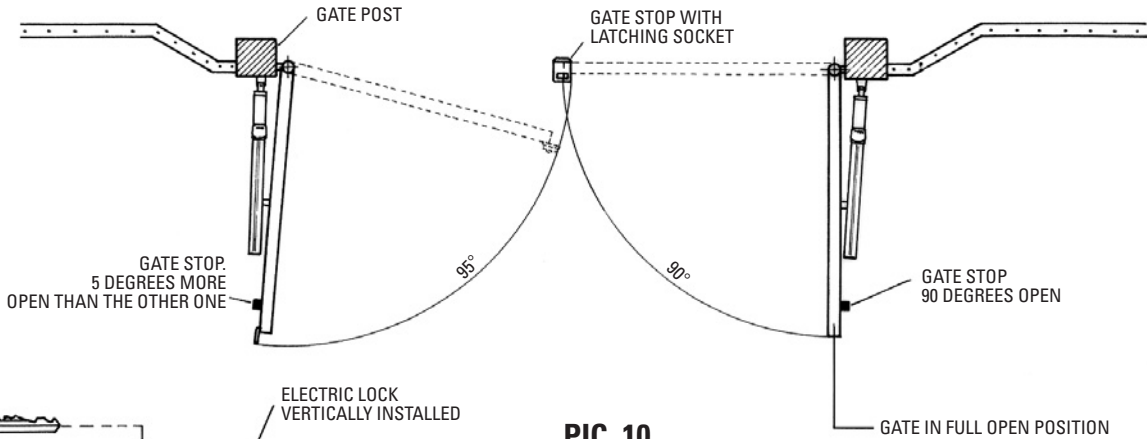

**PIC. 10**

The gate carrying the electric lock must be allowed to open 5 degrees more than the other one to prevent that on approaching the close position the two gates jam into each other. Important: gate stops are to be provided at open gate positions to prevent the pistons from reaching the limit of the permitted stroke. Picture 10.

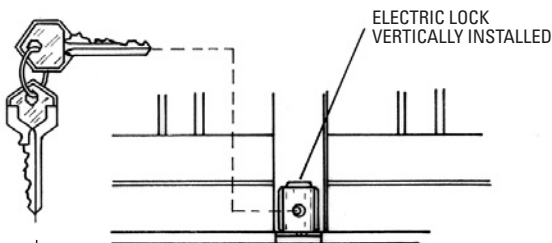

**PIC. 11**

Should a **mechanical latch** be required for better hold of the gates in the close position on to the gate stop, the electric lock is to be fitted horizontally 70 cm from ground level. The gate with the electric lock must open 5 degrees more than the other one.

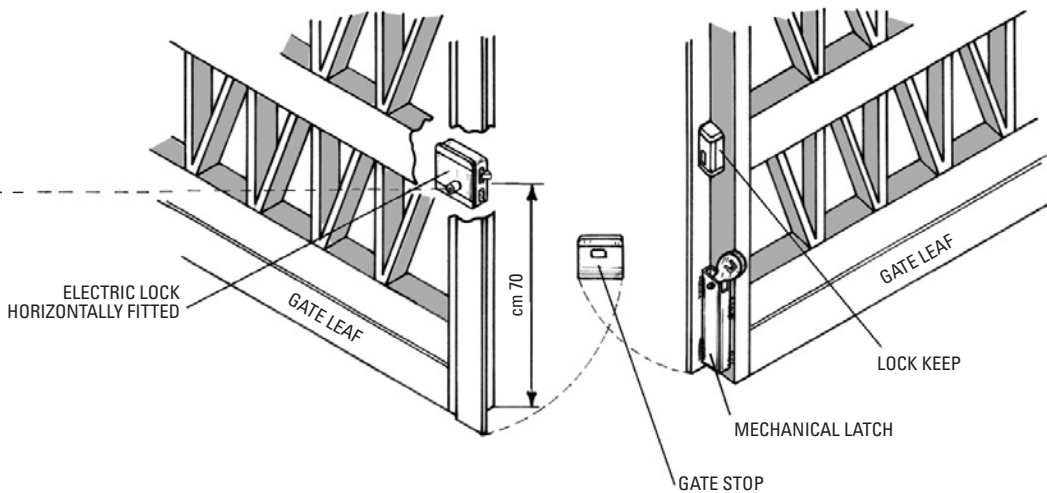

**PIC. 12**

THIS OPERATION IS TO BE DONE ONCE THE PERFORMANCE TESTS ARE FINISHED

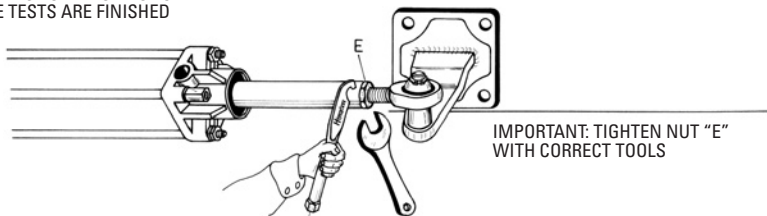

**PIC. 13**

Where brick piers are involved and the gates prehung or the gate hinges are mounted in the middle of the pier, there may be brickwork to cut out in order to allow clearance for the operator between the pier and the open gate. The fixing distances are always to be referred to the centre of the hinge and rear lock nut and bolt. Picture 14-15.

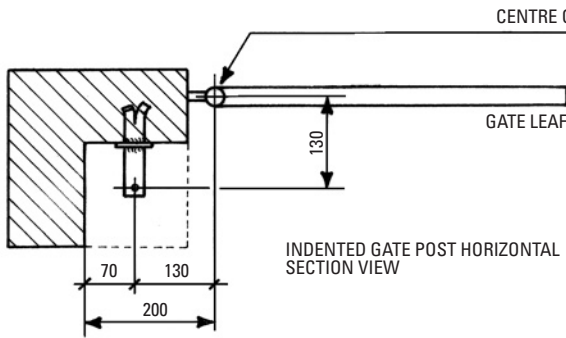

**PIC. 14**

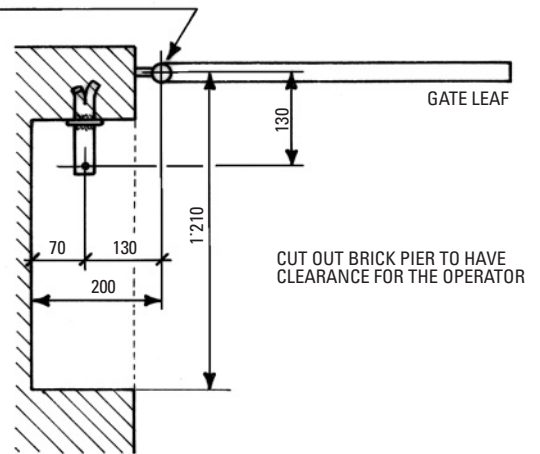

**PIC. 15**

And now the electrical work. Keep to the diagram as shown in picture 18.

**N.W: CARRY OUT A RISK ANALYSIS IN COMPLIANCE WITH EN 12445 AND EN 12453 NORMS AND FIT ANY SAFETY DEVICE WHERE REQUIRED.**

General layout of the system complete with all the recommended accessories. Picture 16.

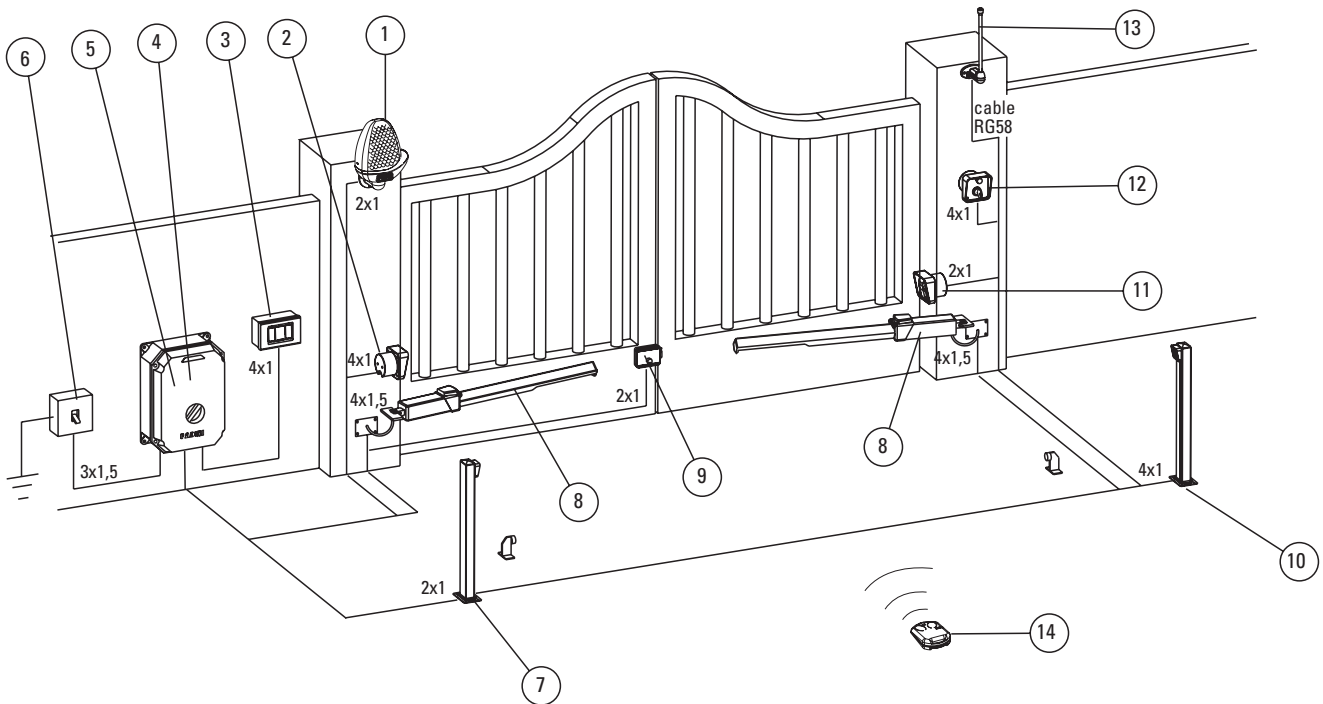

**IMPORTANT:** All the electrical equipment to be properly earthed

**PIC. 16**

- 1 - Flashing lamp MIRI 4
- 2 - Photocell receiver POLO 44
- 3 - Push button PULIN 3
- 4 - Control box ELPRO 13 CEI
- 5 - Plug-in radio receiver ASTRO 43
- 6 - 230V 50/60Hz differential, magnetic thermal mains switch type 0.03A (beyond 100m use cables with 2.5mm Ø)
- 7 - Post with photocell projector POLO 44
- 8 - Electro-hydraulic operator HINDI 880
- 9 - Electric lock
- 10 - Post with photocell receiver POLO 44
- 11 - Photocell transmitter POLO 44
- 12 - Keyswitch PRIT 19
- 13 - Aerial BIRIO A8
- 14 - Radio transmitter ASTRO 43/2 Small

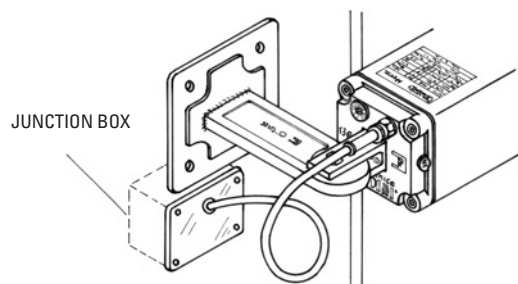

**IMPORTANT:** NO SHARP BEND. SMOOTH LONG LOOP IS RECOMMENDED

**PIC. 17**

# CONNECTION DIAGRAM FOR SWING GATES ELPRO 13 exp

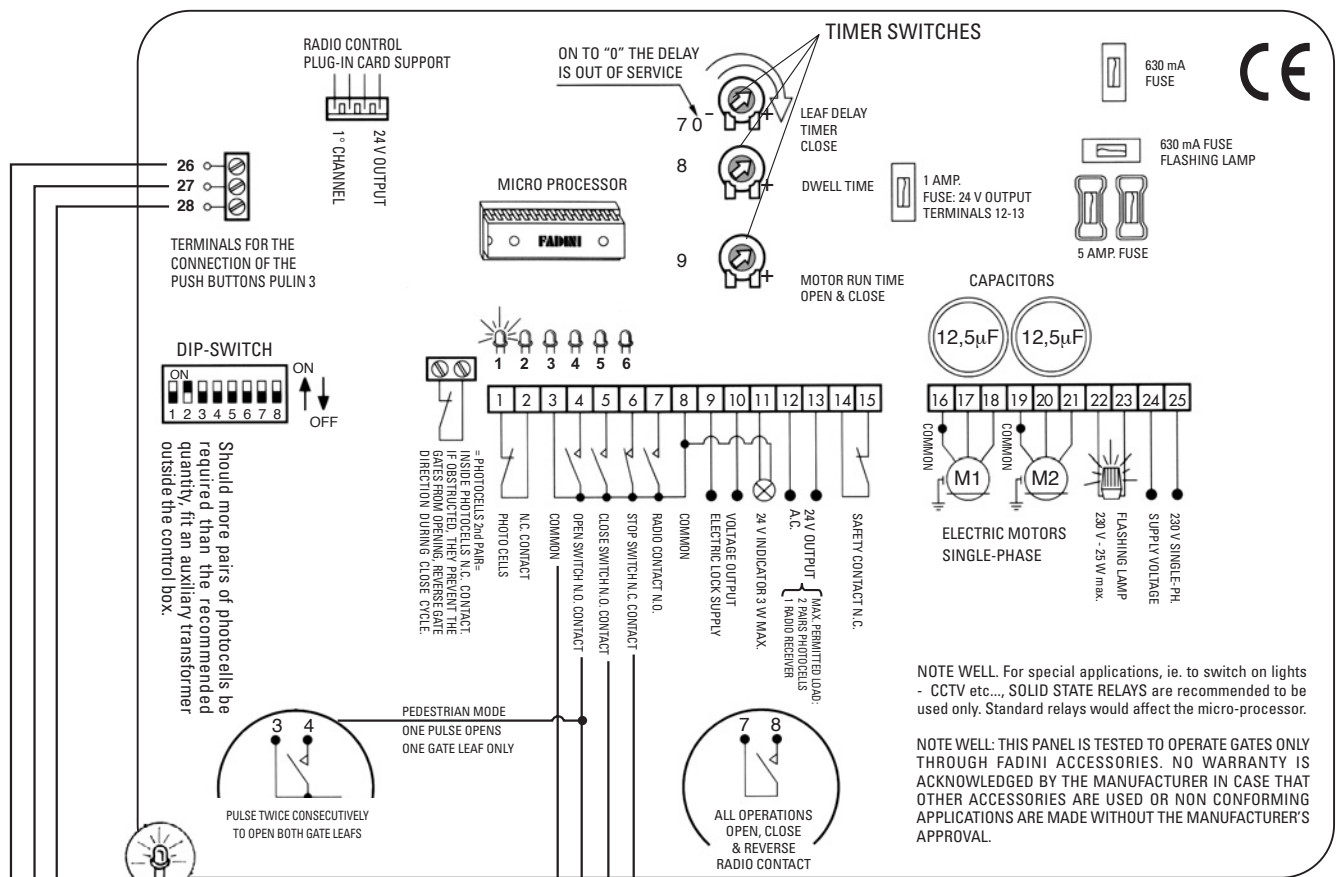

Drwg. No. **1643** P.C. BOARD

## ELECTRICAL WIRING DIAGRAM OF THE ELECTRONIC PROGRAMMER

Once the connections have been made, do the first switching test through the control panel. Set the motor run timer so that the motor is allowed to run 4 - 5 seconds more than the gates. Set the other timers to meet the site requirements. Set DIP switch B No. 3 to **automatic** (ON): on pulsing to 4 - 8 the gates must be operated as pre-set, ie. opening and only after the dwell time, closing. Adjust the times through the respective timers. (See No. 07, 08 and 09 drwg. No. 1643). With DIP switch "B" No. 3 to **semiautomatic** (OFF) one pulse opens the gates, a second pulse to 5 - 8 is needed to close the gates. Any one pulse to 7 - 8 will open, close or reverse the gates independently from the operation being performed. It is recommended to carefully read the instructions in the control box to have all the functions performed correctly.

### The 6 LEDs on the P.C. board indicate the following:

- led No. 1 It switches on when voltage is supplied.
- led No. 2 Photocells. Normally on. It switches off when the photocells are obstructed.
- led No. 3 Open - It switches on when the respective switch is activated.
- led No. 4 Close - It switches on when the respective switch is activated.
- led No. 5 Stop - Normally on. It switches off when the respective switch is activated.
- led No. 6 Radio - It switches on whenever a pulse is given, either from remote control, keyswitch or push buttons.

CONNECTION TO THE "PULIN 3" PUSH BUTTONS WITH STATUS INDICATION LEADS

**PIC. 18**

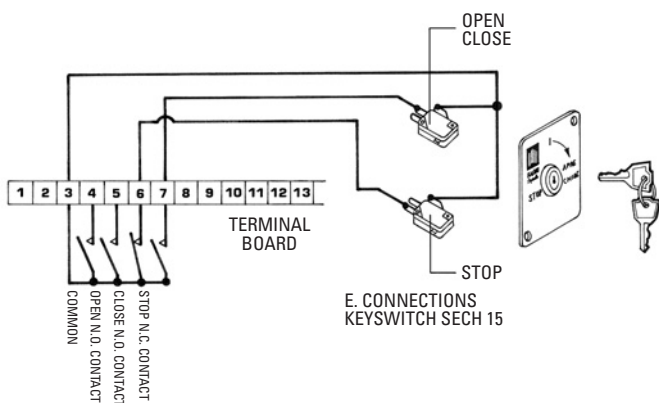

**PIC. 19**

# SPECIAL APPLICATIONS HINDI 880

Drwg. No. 0987 **Hindis880** - 400 mm

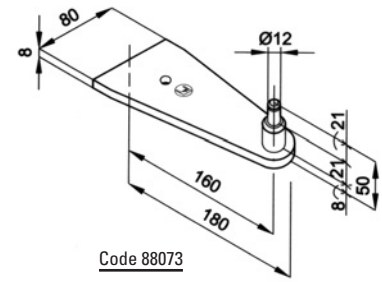
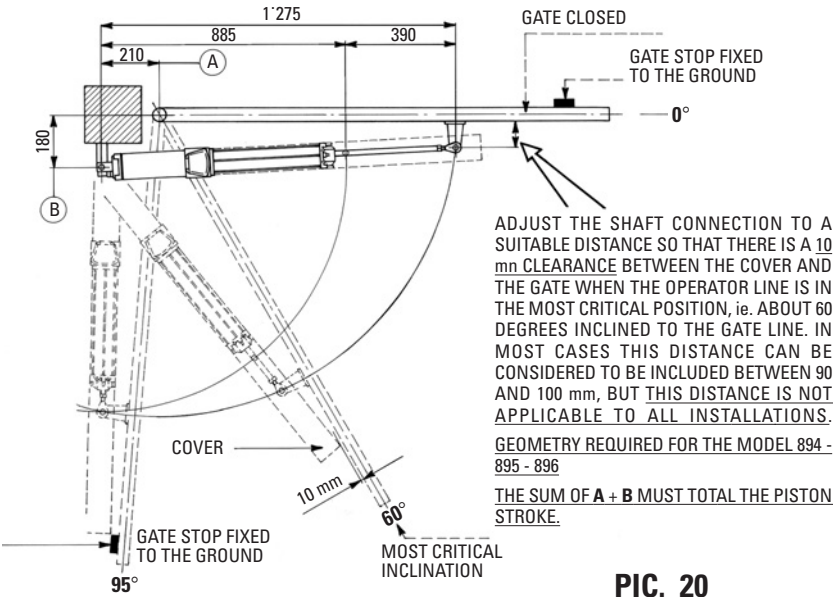

Code 88073  
FRONT FIXING LONGER BRACKET TO SUIT 400 mm RAM

**FIG. 20**

Drwg. No. 1990 **Hindis880** - 150 mm

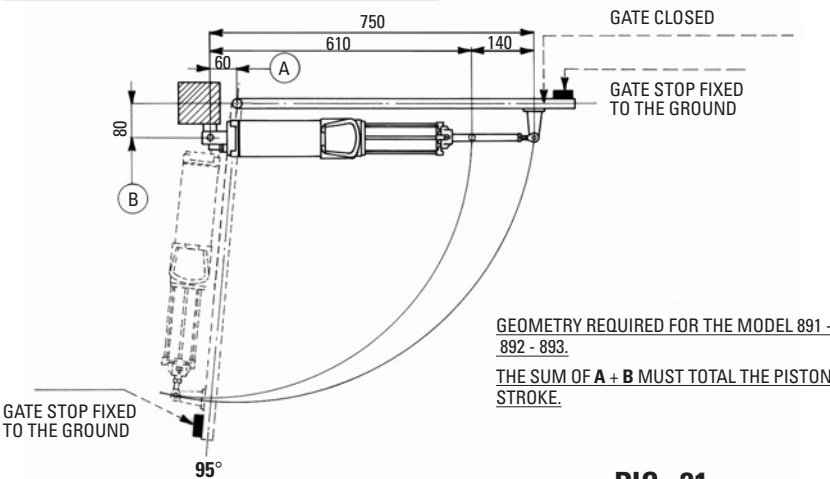
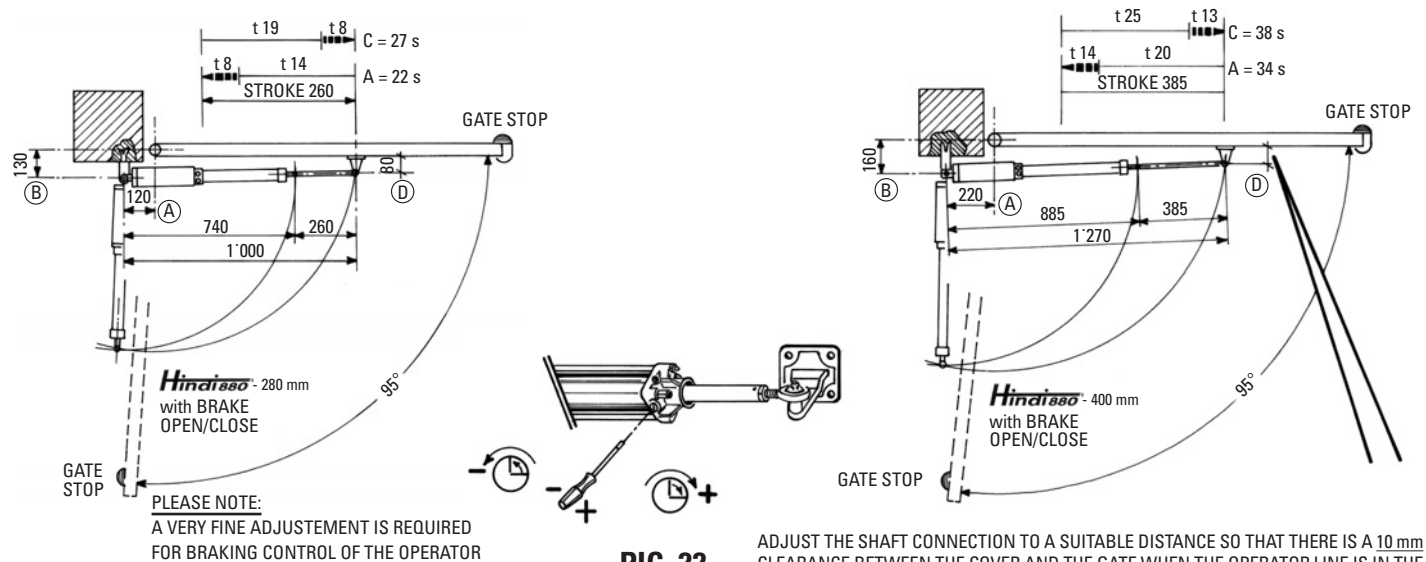

**FIG. 21**

This page specifically refers to the special operators in the Hindi 880 range, ie. drwg. No. 1990 - 150 mm, drwg. No. 0987 - 400 mm stroke and drwg. No. 2552 braking in open/close cycles. The detailed installation instructions that are contained in this manual apply to all the models in the Hindi 880 range.

Only, please note that the items 881 - 891 - 894, that are non locking, have no manual release, and an external electric lock is required to hold the gates in the closed position. A temporary connection to the control panel is to be provided to drive out full movement of the shaft before installation (manual test).

## **Hindis880** SPECIAL VERSIONS. BRAKING IN OPEN/CLOSE CYCLES (Drwg. No. 2552)



**FIG. 22**

ADJUST THE SHAFT CONNECTION TO A SUITABLE DISTANCE SO THAT THERE IS A 10 mm CLEARANCE BETWEEN THE COVER AND THE GATE WHEN THE OPERATOR LINE IS IN THE MOST CRITICAL POSITION, ie. ABOUT 60 DEGREES INCLINED TO THE GATE LINE. IN MOST CASES THIS DISTANCE CAN BE CONSIDERED TO BE INCLUDED BETWEEN 90 AND 100 mm, BUT THIS DISTANCE IS NOT APPLICABLE TO ALL INSTALLATIONS.

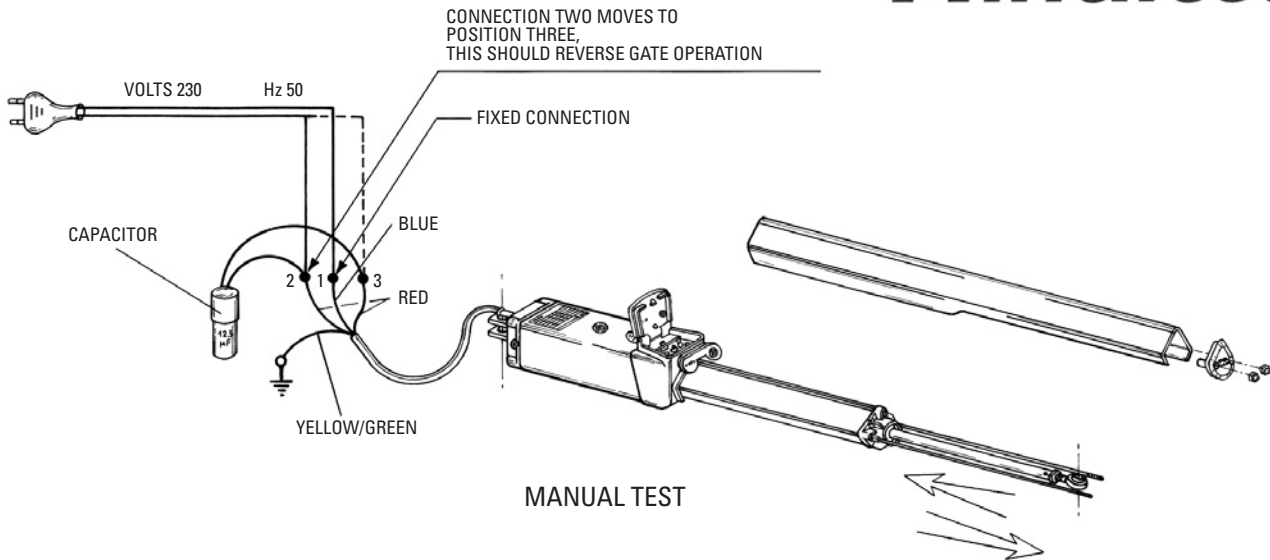

**PIC. 23**

## TECHNICAL SPECIFICATIONS

### OVERALL DIMENSIONS

#### OIL-HYDRAULIC PISTON

|   |  |
|---|--|
| Time for one stroke.....                        | 24 s   |
| Pump flow rate - P5.....                        | 1.4 l/min.                                   |
| Stroke.....                                     | 280 mm                                       |
| Cylinder bore Ø.....                            | 45 mm  |
| Piston shaft Ø.....                             | 20 mm  |
| Thrust power.....                               | 3'000 Nm                                     |
| Working pressure.....                           | 1 MPa (10 bars)                              |
| Max pressure.....                               | 3 MPa (30 bars)                              |
| Oil make.....                                   | Fadini A 15 by AGIP                          |
| Temperature.....                                | - 25°C + 80°C                                |
| Weight of HINDI 880 complete.....               | 11 Kg  |
| Max. gate weight.....                           | 150/180 Kg                                   |
| I.P. standards complete.....                    | IP 553                                       |
| Dimensions (L.xW.xH.).....                      | 1'085x92x110 mm                              |
| Duty cycle.....                                 | 25 sec. Open - 30 sec. Dwell - 25 sec. Close |
| Time of one complete cycle.....                 | 80 s   |
| No. of complete cycles Open - Stop - Close..... | 45/hour                                      |
| No. of cycles a year, 8 hours a day.....        | 131'000                                      |

#### ELECTRIC MOTOR

|                           |                   |
|---------------------------|-------------------|
| Horse power.....          | 0.18 KW (0.25 HP) |
| Voltage.....              | 230 V             |
| Frequency.....            | 50 Hz             |
| Absorbed power.....       | 250 W             |
| Absorbed current.....     | 1.2 A             |
| Motor rotation speed..... | 1'350 r.p.m.      |
| Capacitor.....            | 12.5 µF           |
| Intermittent service..... | S 3               |

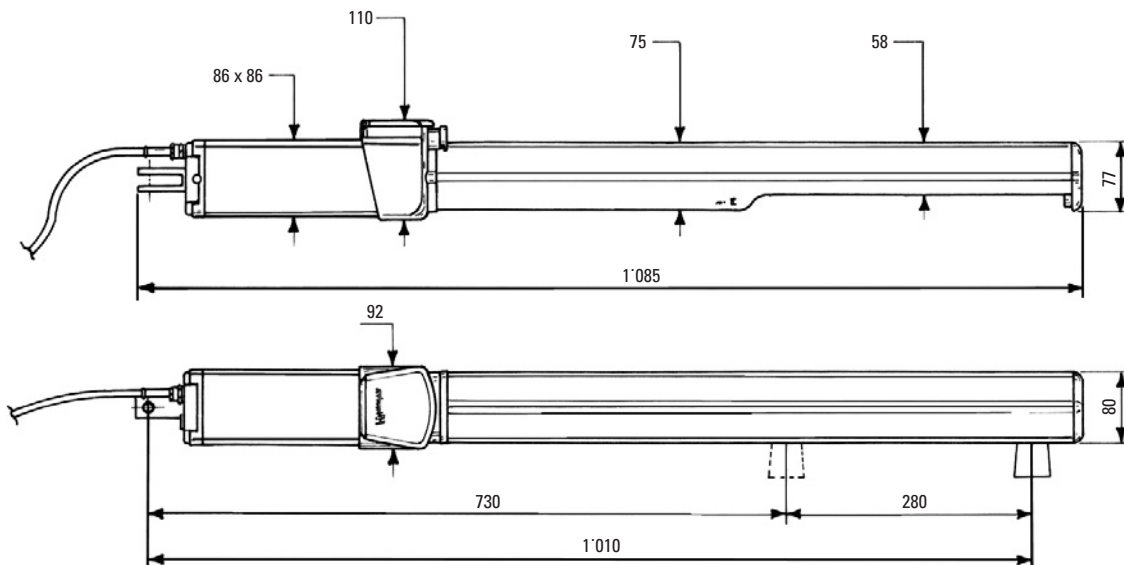

**PIC. 24**

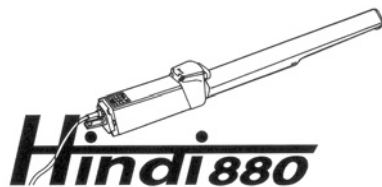

Meccanica Fadini recommends the control panel ELPRO 13 CEI to achieve an installation that is in conformity to the existing safety standards.

The electronic programmer "ELPRO 13" incorporates and can provide all the functions which are required by the most demanding applications with swinging gates.

In addition to the standard features of ELPRO 9 (Drwg. No. 1310), the following requirements can be provided: "stroke reversing pulse", pedestrian mode, stop in any gate position by holding down the remote control button. Among the added features and improvements of "ELPRO 13", in conformity to the European safety standards, there is the mains rotary switch: it is fitted to the box cover and switches off the mains voltage whenever the cover is removed.

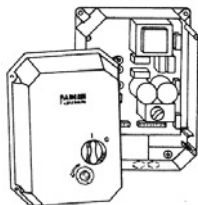

**Elpro 13 CEI**  
SINGLE-PHASE

CUT OFF  
MAINS SWITCH



**EUROPEAN MARK CERTIFYING  
CONFORMITY TO THE ESSENTIAL  
REQUIREMENTS OF THE STANDARDS  
98/37/EC**



**FADINI**  
the gate opener  
Made in Italy



AUTOMATIC GATE MANUFACTURERS

**N.W.**

With all the electro-hydraulic operators, once installed, you need to set the safety pressure valves to meet the gate pushing power/anti-crush requirements. The valve "OPEN" must be set to get higher pressure than "CLOSE". The electric cable is factory-set and must be left free. The encoding remote control, the control box (pre-programmed to meet the most various operation requirements) and a wide range of safety accessories make the system fully automatic.

**CHECKING AND MAINTENANCE:**

To achieve an optimum performance and longer life of the equipment and in observance of the safety regulations, it is recommended that inspections and proper maintenance are made by qualified technicians to the whole installation ie. both the mechanical and electronic parts, as well as wiring.

- Mechanical parts: maintenance every 6 months approx.
- Electronic apparatus and safety equipment: maintenance every month.

**IMPORTANT WARNING NOTES**

- Before installing the equipment carry out a **Risk Analysis** and fit any required device in compliance with EN 12445 and EN 12453 Safety Norms.
- It is recommended to keep to the instructions here outlined. Check the specifications on the motor sticker with your mains supply.
- Dispose properly of the packaging: cardboard, nylon, polystyrene, through specializing companies.
- Should the operator be removed, **do not cut** the electric cable. This must be properly removed from the terminal board in the junction box.
- Switch off the mains switch before removing the junction box cover where the electric cable of HINDI 880 is terminated.
- All the system must be earthed by using the yellow/green wire, marked by its specific symbol.
- It is recommended to read the regulations, suggestions and remarks quoted in the booklet "Warnings".

STICKER FITTED ON TO THE  
ELECTRIC MOTOR

|   |         |    |      |
|---|---------|----|------|
|   |         |    |      |
| Via Mantova, 177/A - 37053 Cerea (VR) Italy - Tel. 0442 330422 r.a. - Fax 0442 331054 |         |    |      |
| MOTOR   | 2 PHASE |    |      |
| W   | 250     | CV | 0.25 |
| VOLTS   | 230     | A  | 1.2  |
| r.p.m.  | 1'350   | Hz | 50   |
| Nm  | 3'000   | μF | 12.5 |
| Degree of protection IP 553   |         |    |      |
| Working pressure max. 3 MPa (30 Bars)   |         |    |      |
| OIL FADINI A15 BY AGIP  |         |    |      |
| MADE IN ITALY   |         |    |      |

- DECLARATION OF CONFORMITY
- GENERAL WARNINGS
- EN 12453, EN 12445 STANDARDS
- CEI EN 60204-1 STANDARDS
- WARRANTY CERTIFICATE ON THE CUSTOMER'S REQUEST

The "CE" mark certifies that the operator conforms to the essential requirements of the European Directive art. 10 EEC 73/23, in relation to the manufacturer's declaration for the supplied items, in compliance with the body of the regulations ISO 9000= UNI EN 29000. Automation in conformity to EN 12453, EN 12445 safety standard.

The growth of MECCANICA FADINI has always been based on the development of guaranteed products thanks to our "TOTAL QUALITY CONTROL" system which ensures constant quality standards, updated knowledge of the European Standards and compliance with their requirements, in view of an ever increasing process of improvement.

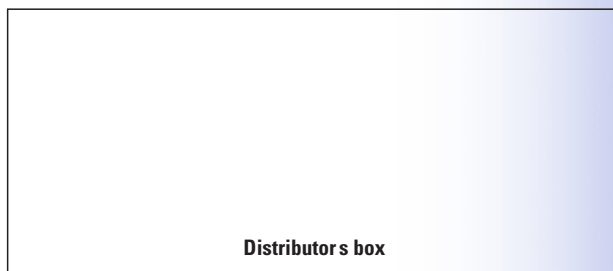

Distributor's box

The manufacturers reserve the right to change the products without any previous notice